

**ELEVATION VIEW**

SCALE: 1/4" = 1'0"

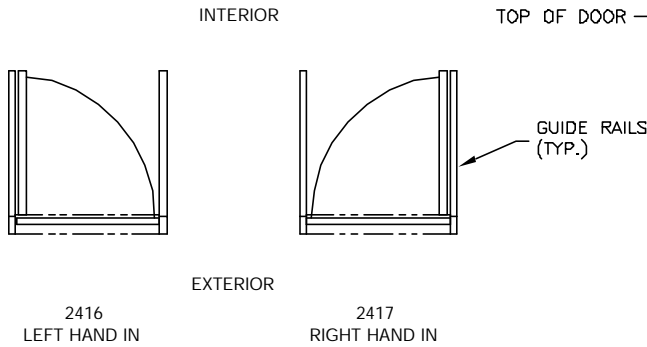

**PLAN VIEW**

SCALE: 1/4" = 1'0"

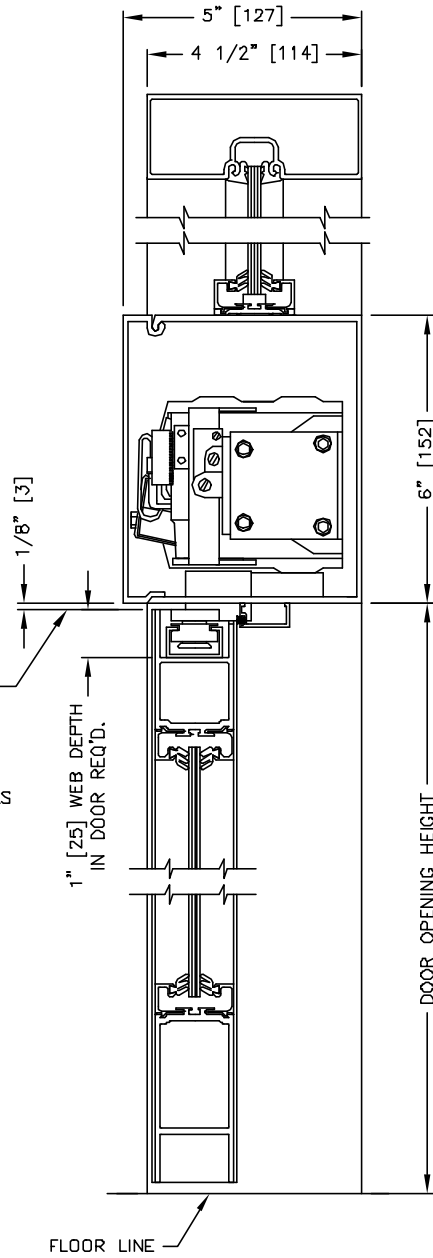

**SECTION: 2**

SCALE: 1/4 SIZE

**NOTES:**

1. IF DOORS AND FRAMES ARE TO BE INCLUDED, UNIT WILL BE SERIES 2600, MODEL 2616 (LH IN) OR 2617 (RH IN).
2. TOP RAIL OF DOOR MUST BE MODIFIED TO PROVIDE CLEARANCE FOR ARM. CONTACT KM SYSTEMS FOR DETAILS.

RH IN (2417) SHOWN.  
LH IN (2416) OPPOSITE.

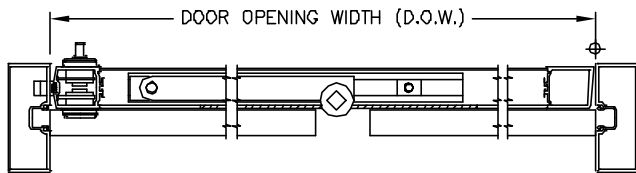

**SECTION: 1**

SCALE: 1/8 SIZE

MEASUREMENTS GIVEN IN INCHES [MILLIMETERS].