



AUTOMATED ENTRANCE SYSTEMS

KM SYSTEMS, INC.

4910 STARCREST DRIVE (28110)
P.O. BOX 3099
MONROE, NC 28111-3099 U.S.A.

AUTOMATIC SWING DOOR OPERATORS

SERIES: 2400 O.H.C. ELECTROHYDRAULIC, FULL FEATURE
MODEL: 2443 (DUAL INDEPENDENT)
TYPE: L.H. DOUBLE EGRESS

PAGE 24-2.05

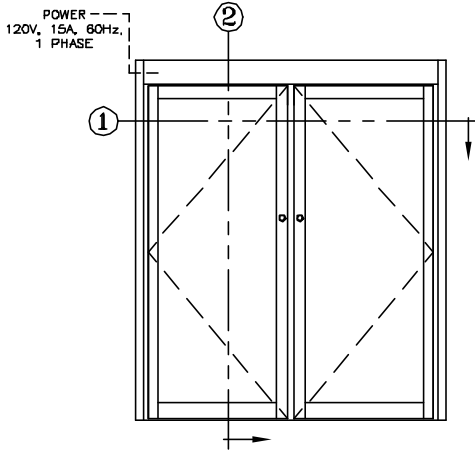

ELEVATION VIEW

SCALE: 1/4" = 1'0"

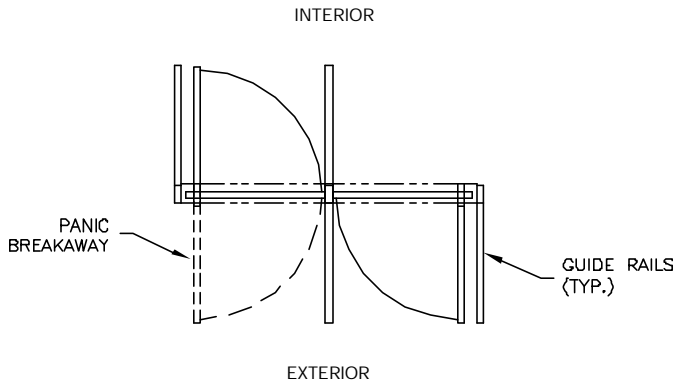

PLAN VIEW

SCALE: 1/4" = 1'0"

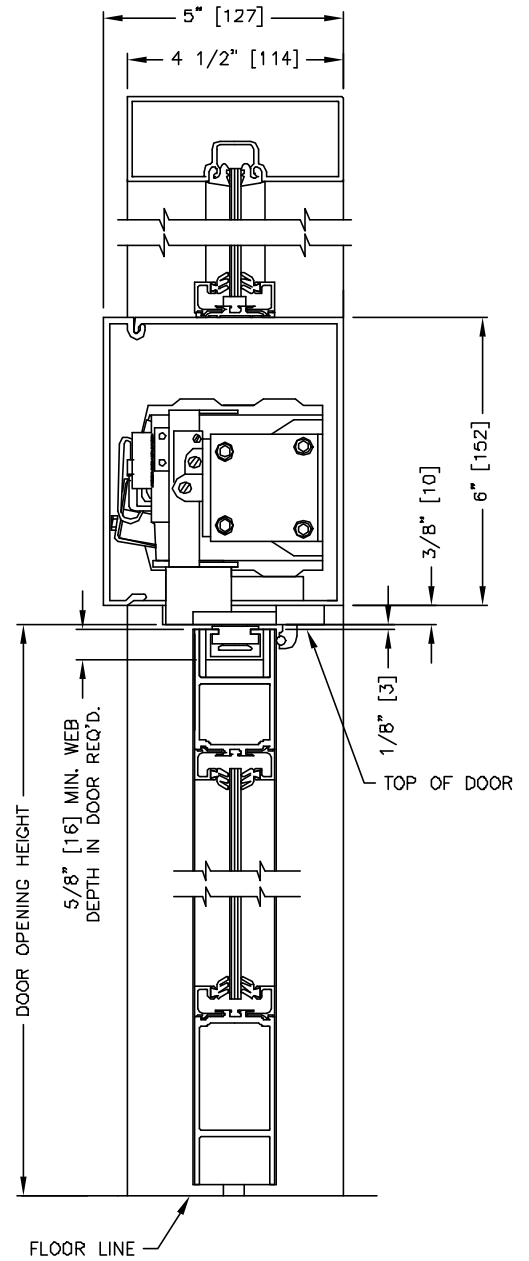

SECTION: 2

SCALE: 1/4 SIZE

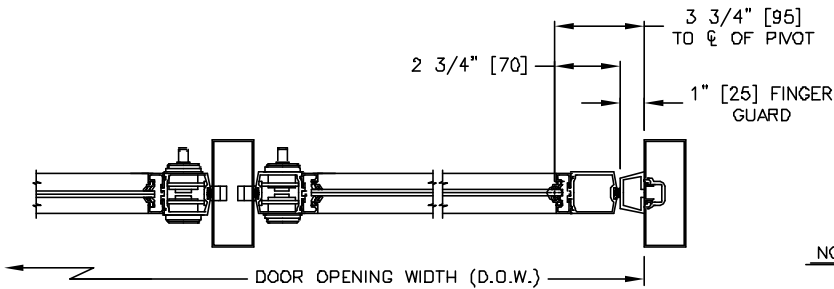

SECTION: 1

SCALE: 1/8 SIZE

NOTE: IF DOORS AND FRAMES ARE TO BE INCLUDED, UNIT WILL BE SERIES 2600, MODEL 2643 (DUAL INDEPENDENT).

MEASUREMENTS GIVEN IN INCHES [MILLIMETERS].