

**ELEVATION VIEW**

SCALE: 1/4" = 1'0"

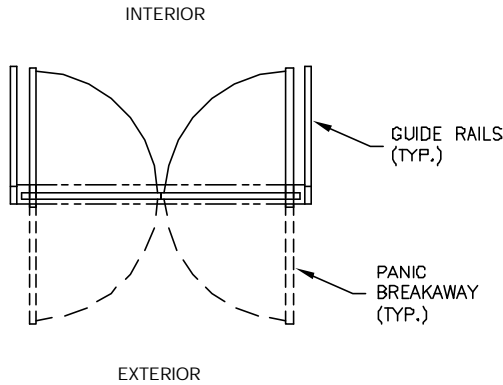

**PLAN VIEW**

SCALE: 1/4" = 1'0"

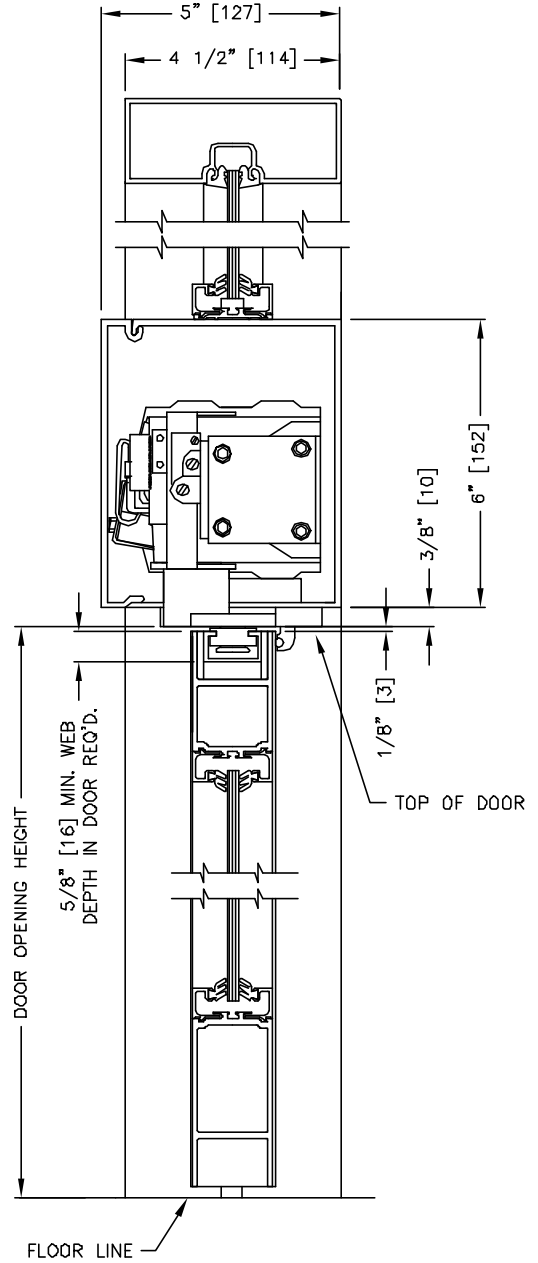

**SECTION: 2**

SCALE: 1/4 SIZE

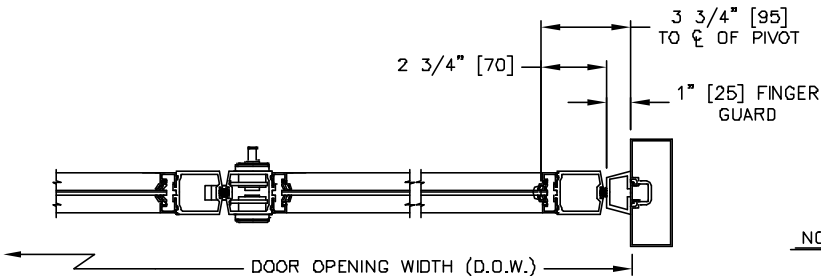

**SECTION: 1**

SCALE: 1/8 SIZE

**NOTE:** IF DOORS AND FRAMES ARE TO BE INCLUDED, UNIT WILL BE SERIES 2600, MODEL 2626 (DUAL SIMULTANEOUS).

MEASUREMENTS GIVEN IN INCHES [MILLIMETERS].