

ELEVATION VIEW

SCALE: 1/4" = 1'0"

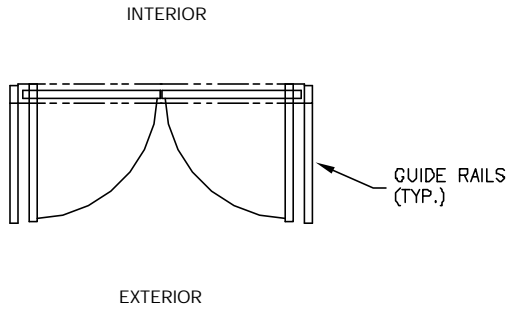

PLAN VIEW

SCALE: 1/4" = 1'0"

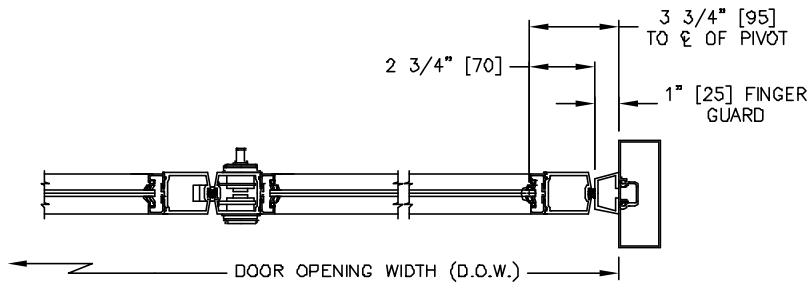

SECTION: 1

SCALE: 1/8" SIZE

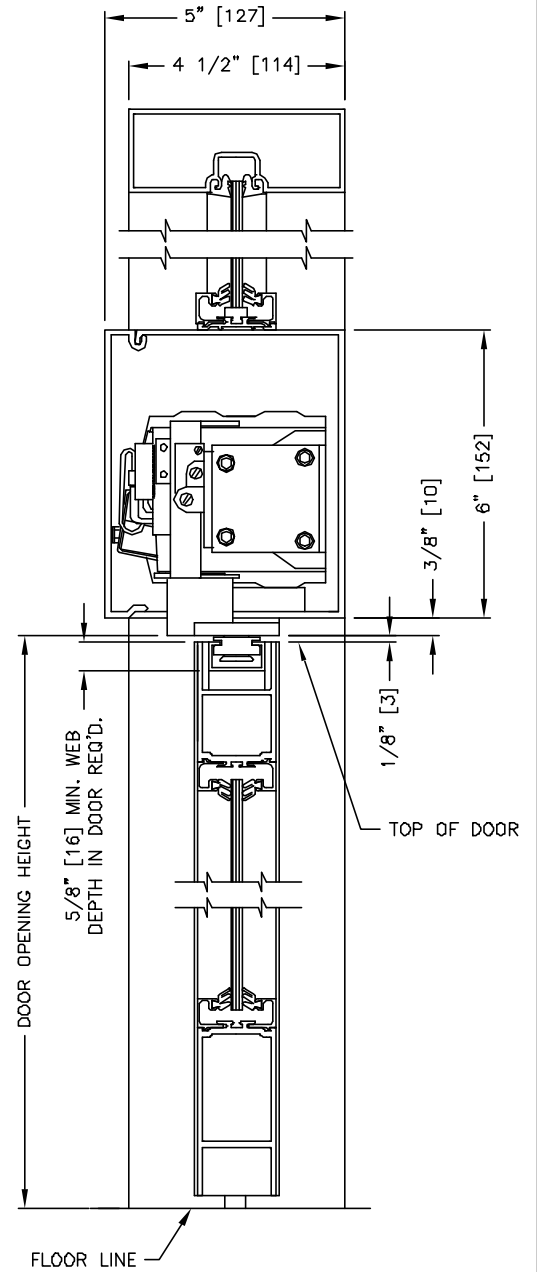

SECTION: 2

SCALE: 1/4" SIZE

NOTE: IF DOORS AND FRAMES ARE TO BE INCLUDED, UNIT WILL BE SERIES 2600, MODEL 2622 (DUAL SIMULTANEOUS).

MEASUREMENTS GIVEN IN INCHES [MILLIMETERS].