

POWER
120V, 15A, 60HZ,
1 PHASE

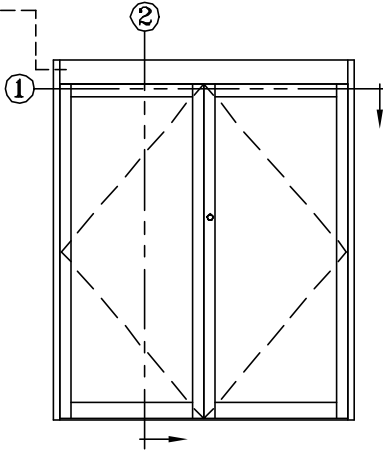

ELEVATION VIEW

SCALE: 1/4" = 1'0"

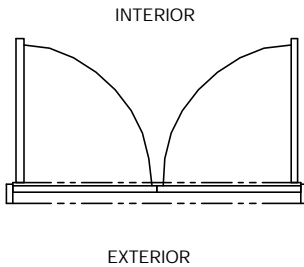

PLAN VIEW

SCALE: 1/4" = 1'0"

NOTE:

TOP RAIL OF DOOR MUST BE MODIFIED
TO PROVIDE CLEARANCE FOR ARM.
CONTACT KM SYSTEMS FOR DETAILS.

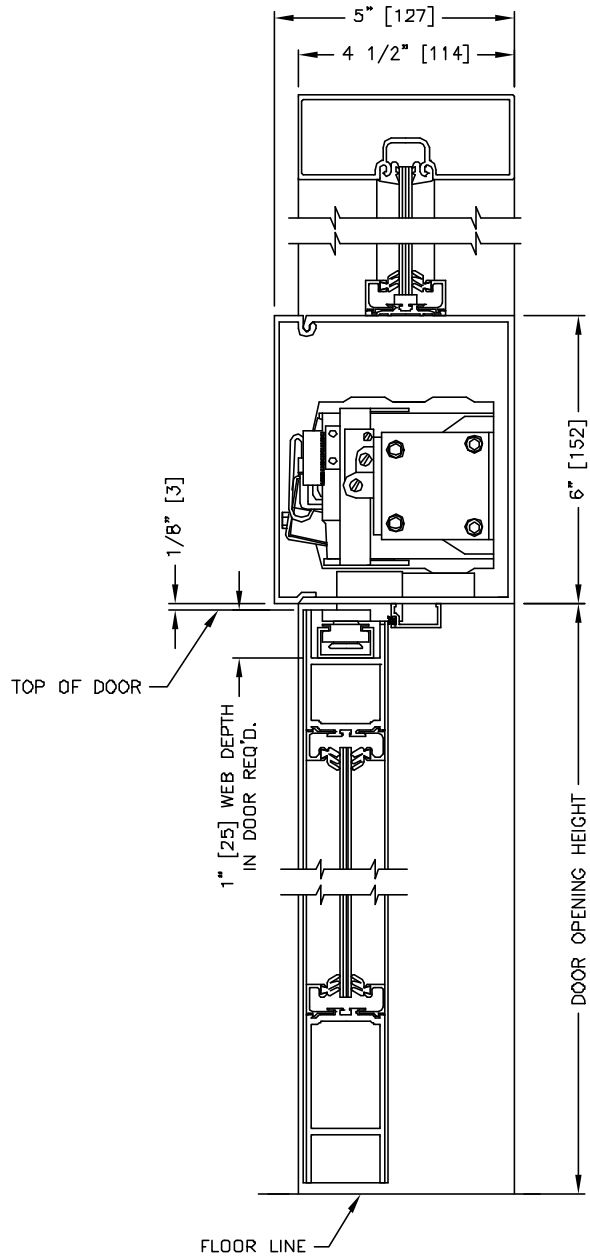

SECTION: 2

SCALE: 1/4" SIZE

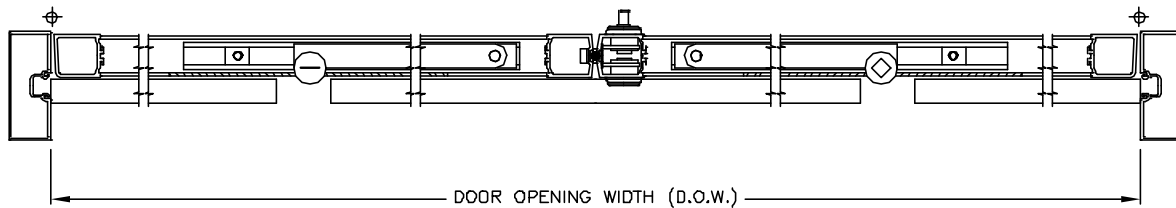

SECTION: 1

SCALE: 1/8" SIZE

MEASUREMENTS GIVEN IN INCHES [MILLIMETERS].