



AUTOMATED ENTRANCE SYSTEMS

KM SYSTEMS, INC.

4910 STARCREST DRIVE (28110)
P.O. BOX 3099
MONROE, NC 28111-3099 U.S.A.

AUTOMATIC SWING DOOR OPERATORS

SERIES: 2000 ELECTROHYDRAULIC, FULL FEATURE
MODEL: 2033 (DUAL SIMULTANEOUS) OR 2043 (DUAL INDEPENDENT)
TYPE: L.H. DOUBLE EGRESS (WITH BREAKAWAY)

PAGE 20-2.10

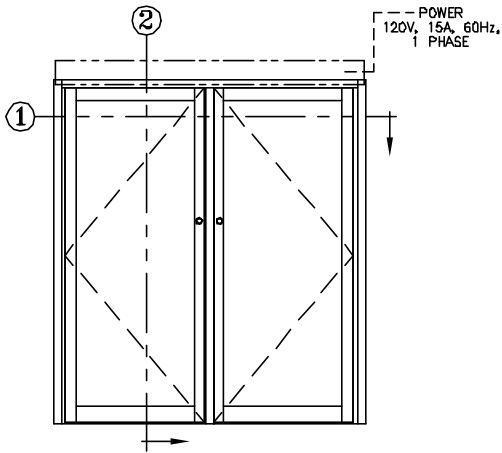

ELEVATION VIEW

SCALE: 1/4" = 1'0"

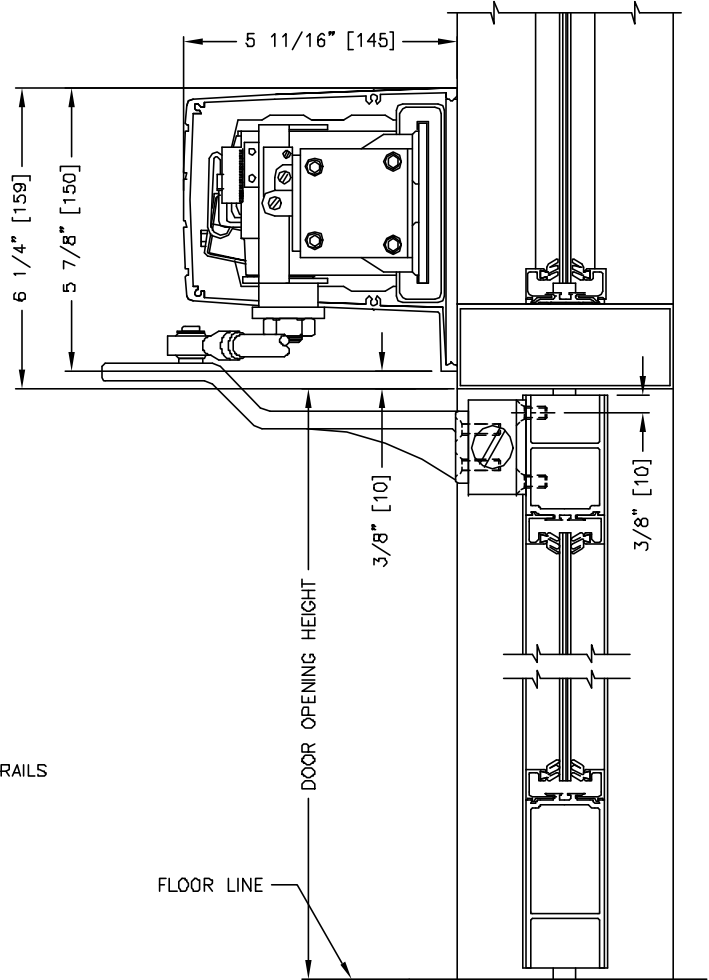

SECTION: 2

SCALE: 1/4 SIZE

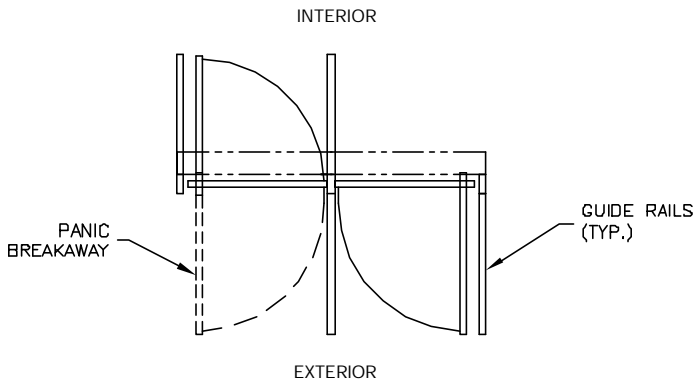

PLAN VIEW

SCALE: 1/4" = 1'0"

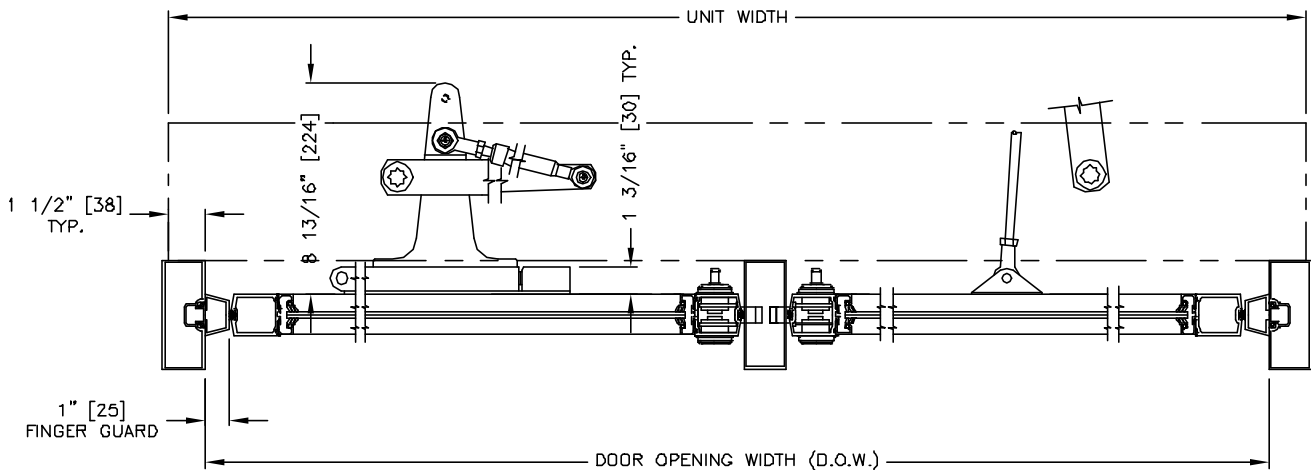

SECTION: 1

SCALE: 1/8 SIZE

MEASUREMENTS GIVEN IN INCHES [MILLIMETERS].