

POWER  
120V, 15A, 60Hz,  
1 PHASE

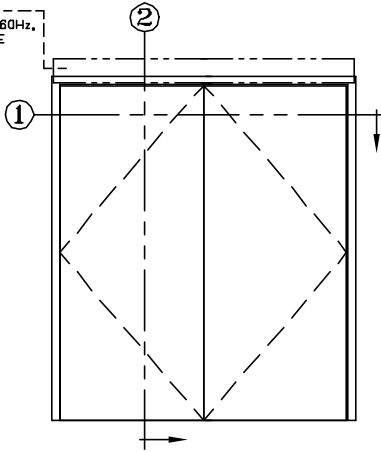

**ELEVATION VIEW**

SCALE: 1/4" = 1'0"

INTERIOR

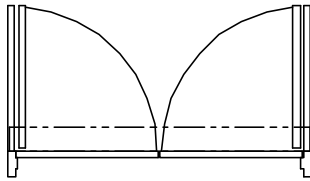

EXTERIOR

**PLAN VIEW**

SCALE: 1/4" = 1'0"

WOOD BLOCKING/STRUCTURAL SUPPORT  
(SEE NOTE)

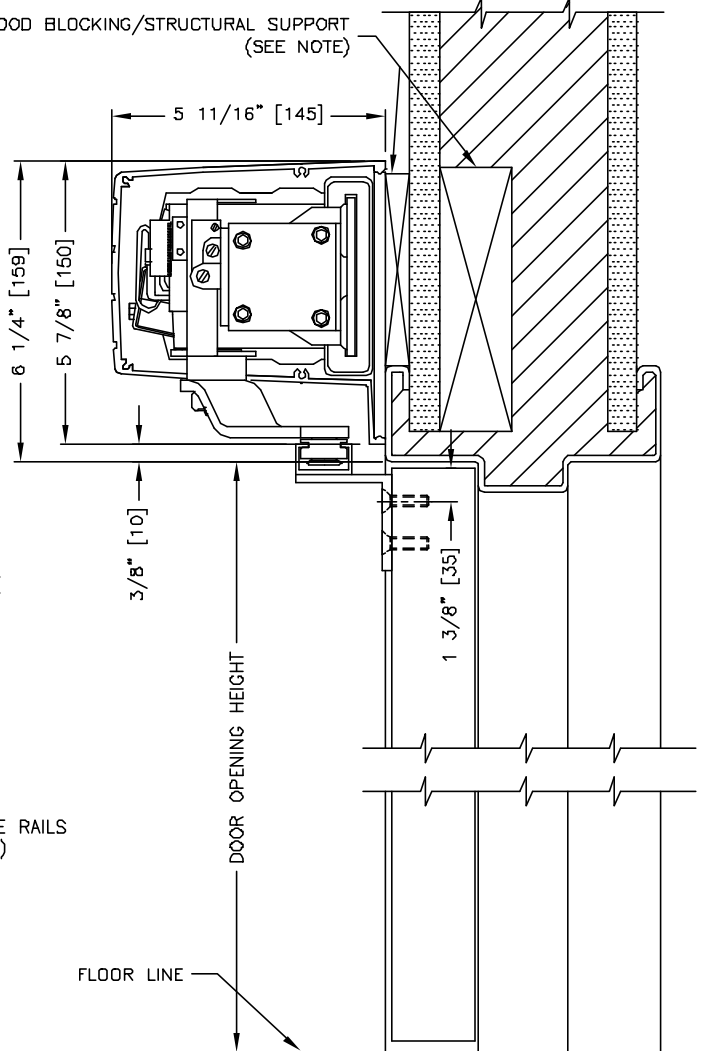

**SECTION: 2**

SCALE: 1/4 SIZE

**NOTES:**

1. WOOD BLOCKING/STRUCTURAL SUPPORT FOR DOOR OPERATOR (BY OTHERS).
2. 2-1/2" FOR REVEAL 0" - 1/2"  
3-1/2" FOR REVEAL 9/16" - 1-1/2"

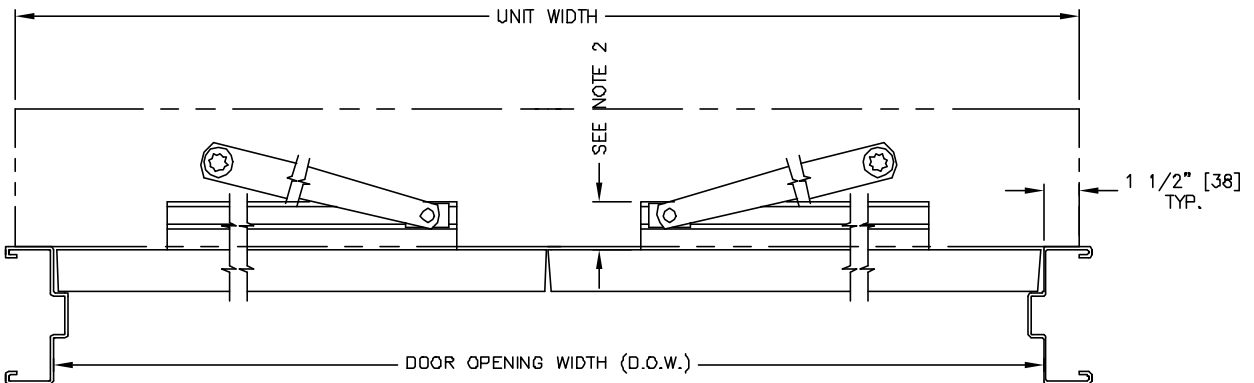

**SECTION: 1**

SCALE: 1/8 SIZE

MEASUREMENTS GIVEN IN INCHES [MILLIMETERS].