

ELEVATION VIEW

SCALE: 1/4" = 1'0"

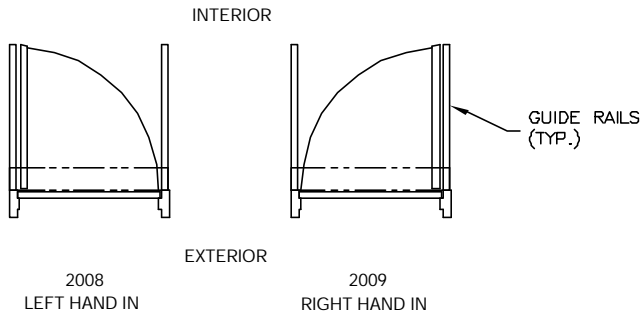

PLAN VIEW

SCALE: 1/4" = 1'0"

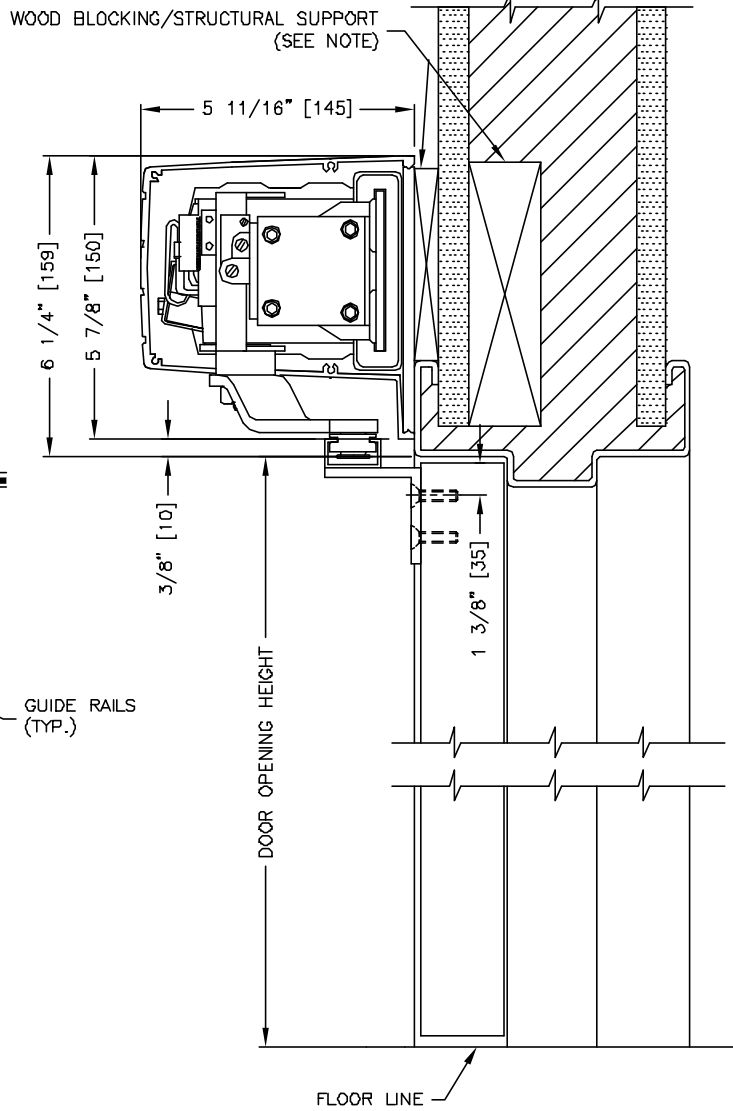

SECTION: 2

SCALE: 1/4 SIZE

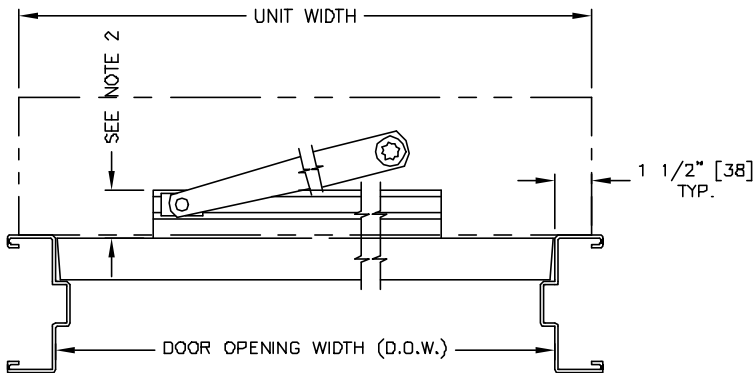

SECTION: 1

SCALE: 1/8 SIZE

NOTES:

1. WOOD BLOCKING/STRUCTURAL SUPPORT FOR DOOR OPERATOR (BY OTHERS).
2. 2-1/2" FOR REVEAL 0" - 1/2"
3-1/2" FOR REVEAL 9/16" - 1-1/2"

RH IN (2009) SHOWN.
LH IN (2008) OPPOSITE.

MEASUREMENTS GIVEN IN INCHES [MILLIMETERS].